

Features

TrueAlarm photoelectric smoke sensing *and* heat sensing combined in one housing to provide:

- Smoke activity accurately monitored by TrueAlarm photoelectric sensing technology
- Thermal activity accurately monitored by TrueAlarm thermistor sensing technology
- And **TrueSense detection**, a correlation of smoke activity and thermal activity providing intelligent fire detection earlier than with either activity alone

For use with Simplex® 4100ES, 4010ES, and 4100U fire alarm control panels:

- TrueAlarm analog sensor information is digitally communicated to the control panel via IDNet two-wire communications
- Special point types allow the 4098-9754 multi-sensor to communicate smoke and heat analog sensing data *using only one IDNet address*
- Individual sensor information is processed by the host control panel to determine sensor status and to determine whether conditions are normal, off-normal, or alarm
- (4100U fire alarm control panels require software revision 11 or higher with multi-point compatible IDNet transmission modules)

Alarms can be determined by either:

- Smoke detection with selectable sensitivity from 0.2 to 3.7 %/ft obscuration (refer to additional information on page 2)
- Heat detection selectable as fixed temperature or fixed with selectable rate-of-rise
- TrueSense intelligent analysis of the combination of smoke and heat activity

Additional design features:

- Functional and architecturally styled enclosures for ceiling or wall mounting
- Smoke sensor louver design that directs air flow to chamber enhancing smoke capture
- Built-in magnetic test feature
- Compatible with standard bases (including relay control), sounder bases, and isolator bases
- Designed for EMI compatibility

UL listed to Standard 268

* This product has been approved by the California State Fire Marshal (CSFM) pursuant to Section 13144.1 of the California Health and Safety Code. See CSFM Listings 7272-0026:218 and 7300-0026:217 for allowable values and/or conditions concerning material presented in this document. Accepted for use – City of New York Department of Buildings – MEA35-93E. Refer to page 4 for ULC listing status. Additional listings may be applicable; contact your local Simplex product supplier for the latest status. Listings and approvals under Simplex Time Recorder Co. are the property of Tyco Fire Protection Products.

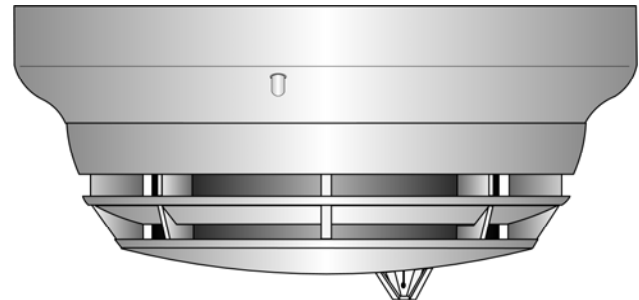

TrueAlarm Multi-Sensor 4098-9754
Mounted in Standard Sensor Base

TrueAlarm Multi-Sensor Description

TrueAlarm multi-sensor model 4098-9754 combines the established performances of a TrueAlarm photoelectric smoke sensor with a fast-acting and accurate TrueAlarm thermal sensor to provide both features in a single sensor/base assembly.

Digital Communication of Analog Sensing.

Analog information from each sensor is digitally communicated to the control panel where it is analyzed. Photoelectric sensor input is stored and tracked as an average value with an alarm or abnormal condition being determined by comparing the sensor's present value against its average value. Thermal data is processed to look for absolute or rate-of-rise temperature as desired.

Intelligent Data Evaluation. Monitoring each photoelectric sensor's average value provides a software filtering process that compensates for environmental factors (dust, dirt, etc.) and component aging, providing an accurate reference for evaluating new activity. The result is a significant reduction in the probability of false or nuisance alarms caused by shifts in sensitivity, either up or down. Status indications of dirty and excessively dirty are automatically generated allowing maintenance to be performed per device.

Control Panel Selection. Peak activity per sensor is stored to assist in evaluating specific locations. The alarm set point for each TrueAlarm sensor is determined at the control panel, selectable as more or less sensitive as the individual application requires.

Multi-Point Reporting and CO Base Reference.

Reporting 4098-9754 "sub-points" under its single address varies with the base used. Multi-point details are listed in data sheet S4090-0011.

Using the 4098-9754 with CO sensor bases is detailed in data sheet S4098-0052.

Description (Continued)

Timed/Multi-Stage Selection. Alarm set points can be programmed for timed automatic sensitivity selection (such as more sensitive at night, less sensitive during day). Control panel programming can also provide multi-stage operation per sensor. For example, a 0.2% level may cause a warning to prompt investigation while a 2.5% level may initiate an alarm.

Sensor Alarm and Trouble LED Indication. Each sensor base's LED pulses to indicate communications with the panel. If the control panel determines that a sensor is in alarm, or that it is dirty or has some other type of trouble, the details are annunciated at the control panel and that sensor base's LED will be turned on steadily. During a system alarm, the control panel will control the LEDs such that an LED indicating a trouble will return to pulsing to help identify the alarmed sensors.

TrueAlarm Analog Sensor Features

General mechanical:

- Housing is sealed against rear air flow entry
- Electronics are EMI/RFI shielded

Smoke sensing:

- Photoelectric light scattering sensing technology
- 360° smoke entry for optimum response
- Chamber screen provides protection from dirt, dust, and insects

Heat sensing:

- Fast response thermistor design
- Rate compensated, self-resetting operation
- Control panel can select per sensor for fixed temperature sensing, rate-of-rise temperature sensing, or the combination of both

Photoelectric Sensing Details

TrueAlarm photoelectric sensors use a stable, pulsed infrared LED light source and a silicon photodiode receiver to provide consistent and accurate low power smoke sensing. Seven levels of sensitivity are available for each individual sensor, ranging from 0.2% to 3.7% per foot of smoke obscuration. Sensitivities of 0.2%, 0.5%, and 1% are for special applications in clean areas. Standard sensitivities are 1.5%, 2.0%, 2.5%, 3.0%, and 3.7%. Application type and sensitivity are selected and then monitored at the fire alarm control panel.*

Sensor head design provides 360° smoke entry for optimum smoke response. Because of the photoelectric sensing technology, the 4098-9754 sensor is UL listed for air velocity of up to 4000 ft/min. However, care must be taken in determining sensor locations to avoid areas where local airflow may also impact any smoke flow. (Refer to the application reference section on this page.)

Heat Sensing Details

TrueAlarm heat sensors monitor a fast reacting thermistor providing operation that is self-restoring and rate compensated. Due to its small thermal mass, the sensor accurately and quickly measures the local temperature for analysis at the fire alarm control panel. The control panel allows alarm selection to be per sensor as fixed temperature, or rate-of-rise temperature, or the combination of both.

Temperature Detection. Rate-of-rise temperature detection is selectable at the control panel for either 15° F (8.3° C) or 20° F (11.1° C) per minute. Fixed temperature sensing is independent of rate-of-rise sensing and selectable to operate at 135° F (57.2° C) or 155° F (68° C). In a slow developing fire, the temperature may not increase rapidly enough to operate the rate-of-rise feature. However, an alarm will be initiated when the temperature reaches its selected fixed temperature setting.

Utility Temperature Monitoring. TrueAlarm heat sensors can be programmed as a utility device to monitor for temperature extremes in the range from 32° F to 122° F (0° C to 50° C). This feature can provide freeze warnings or alert to HVAC system problems.

TrueSense Detection Details

Control Panel Sensor Analysis. Each multi-sensor's smoke and heat sensing element provides data for evaluation at the fire alarm control panel where four independent detection modes are evaluated. They are:

- Fixed temperature heat detection
- Rate-of-rise heat detection
- TrueAlarm photoelectric smoke detection
- And TrueSense correlation detection

Comparing Photoelectric Activity and Thermal Activity

TrueSense analysis correlates both thermal activity *and* smoke activity at a single multi-sensor location using an extensively tested covariance relationship. As a result, TrueSense detection improves response to conditions indicative of faster acting, hot flaming fires when compared to the response of either photoelectric smoke activity or thermal activity alone.

High Integrity Detection. TrueSense operation provides early fire detection and maintains the established high level of immunity to false alarms and nuisance alarms that is inherent with TrueAlarm sensor operation.

Application Reference

Sensor locations should be determined after careful consideration of the physical layout and contents of the area to be protected. Refer to NFPA 72, the *National Fire Alarm and Signaling Code*. On smooth ceilings, smoke sensor spacing of 30 ft (9.1 m) may be used as a guide.*

* For detailed application information, refer to *4098 Detectors, Sensors, and Bases Application Manual*, document number 574-709.

Multi-Sensor Base Features

Base mounted address selection allows the address of the multi-sensor base to remain with its programmed location when the sensor is removed for service.

Integral red LED indicates power-on by pulsing, or alarm or trouble when steady on, reflecting status of either sensor. The exact status of the specific sensing element is annunciated at the fire alarm control panel.

Fire Alarm Control Panel Features

- Individual smoke sensitivity and temperature operation is selectable for each sensor
- Sensitivity monitoring that satisfies NFPA 72 sensitivity testing requirements

Fire Alarm Control Panel Features (Cont'd)

- Peak value logging allows accurate analysis for sensitivity selection
- Automatic, once per minute individual sensor calibration check verifies sensor integrity
- Multi-stage alarm operation
- Selectable alarm verification
- Automatic environmental compensation and determination of dirty and excessively dirty
- TrueSense analysis of smoke and heat activity
- Ability to display and print detailed sensor information in plain English language
- Smoke sensitivity displayed in percent per foot and temperature readings selectable as Fahrenheit or Celsius

Mounting Reference

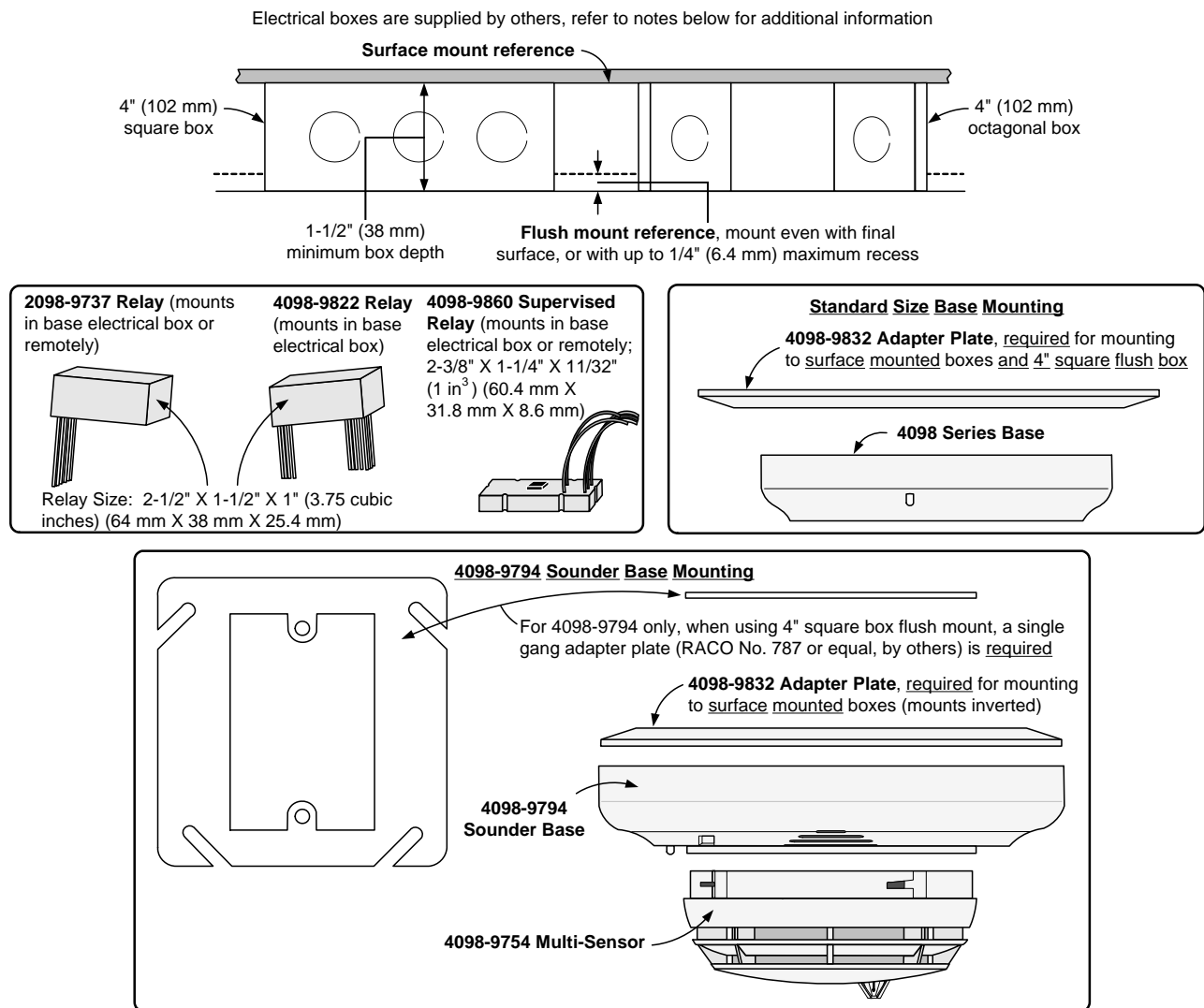

NOTES:

1. Review wire size, wire count, box type, and whether a locally mounted relay is used before determining box size.
2. When a locally mounted relay is used, mount relay in electrical box and use 1-1/2" extension ring (by others) on 4" square or octagonal box of 1-1/2" or 2-1/8" depth as required.
3. Flush mounting also fits a single gang box, 2-1/8" (51 mm) deep if compatible with wiring requirements. (Not applicable if a locally mounted relay is used.)
4. Refer to Systems Manual 574-709 for additional information.

Product Selection

TrueAlarm Multi-Sensor (ordered separately, refer to page 3 for mounting requirements)

Model	Description
4098-9754	Multi-sensor, photoelectric sensor with integral thermal sensor; select base from list below

TrueAlarm Multi-Sensor Bases (ordered separately, refer to page 3 for mounting requirements)

Model	Description	For More Detail See Data Sheet
4098-9792	Standard Sensor Base, no options	S4098-0019
4098-9789	Sensor Base with connections for remote LED alarm indicator or unsupervised relay	
4098-9791	4-Wire Sensor Relay Base	
4098-9780	2-Wire Sensor Relay Base	Includes connections for Supervised Remote Relay and for remote LED alarm indicator or unsupervised relay; see below for details
4098-9793	Isolator Base with built-in IDNet communications isolator, no options	S4098-0025
4098-9794	Sounder Base with connections for remote LED alarm indicator or unsupervised relay	S4098-0028

Accessories Reference (ordered separately as required, refer to page 3 for additional mounting requirements)

Model	Description	
4098-9832	Adapter Plate, 6-3/8" (162 mm) diameter, 1/4" (6.4 mm) deep, matches bases, see page 3 for required applications	
2098-9808	Red LED Alarm Indicator on single gang stainless steel plate, mounts on single gang box, 1-1/2" (38 mm) minimum depth	
4098-9822	Choose one if applicable Relay with operation that tracks base led status , mounts in base electrical box, 4" square or octagonal box with 1-1/2" (38 mm) extension ring, select box depth per actual wiring requirements; DPDT contacts for resistive/suppressed loads, power limited rating of 2 A @ 28 VDC; non-power limited rating of 1/2 A @ 120 VAC, (requires external 24 VDC coil power)	
2098-9737	Supervised Relay for use with 4098-9791 only ; DPDT contacts for resistive/suppressed loads, power limited rating of 3 A @ 28 VDC; non-power limited rating of 3 A @ 120 VAC (requires external 24 VDC coil power)	Mount remotely or in base electrical box; remote mounting requires 4" octagonal or 4" square box, 1-1/2" minimum depth; base mounting requires 4" octagonal box, 2-1/8" deep with 1-1/2" extension ring; see page 3 for dimension reference
4098-9860	Supervised Relay for use with 4098-9780 only ; SPDT dry contacts, power limited rating of 2 A @ 30 VDC, resistive; non-power limited rating of 0.5 A @ 125 VAC, resistive	

Specifications

General Operating Specifications (refer to data sheet list for additional detail)

Communications and Sensor Supervisory Power	4100ES, 4100U, or 4010ES IDNet communications, 1 address per base
UL Listed Operating Temperature Range	32° F to 100° F (0° C to 38° C)
Operating Temperature Range	15° F to 122° F (-9° C to 50° C)
Storage Temperature Range	0° F to 140° F (-18° C to 60° C)
Humidity Range	10 to 95% RH
Smoke Sensor Sensitivity Range	0.2 % to 3.7% per foot of smoke obscuration, selected at control panel (refer to additional information on page 2)
Smoke Sensor Air Velocity Range	0-4000 ft/min (0-1220 m/min)
Thermal Sensor Operation (selected at control panel)	Fixed alarm temperature setting of 135° F (57.2° C), and/or rate-of-rise temperature alarm at 15° F (8.3° C) or 20° F (11.1° C), also selectable as utility monitoring operation from 32° F to 122° F (0° C to 50° C)
Housing Color	Frost White

4098-9754 Sensor and Base Dimensions

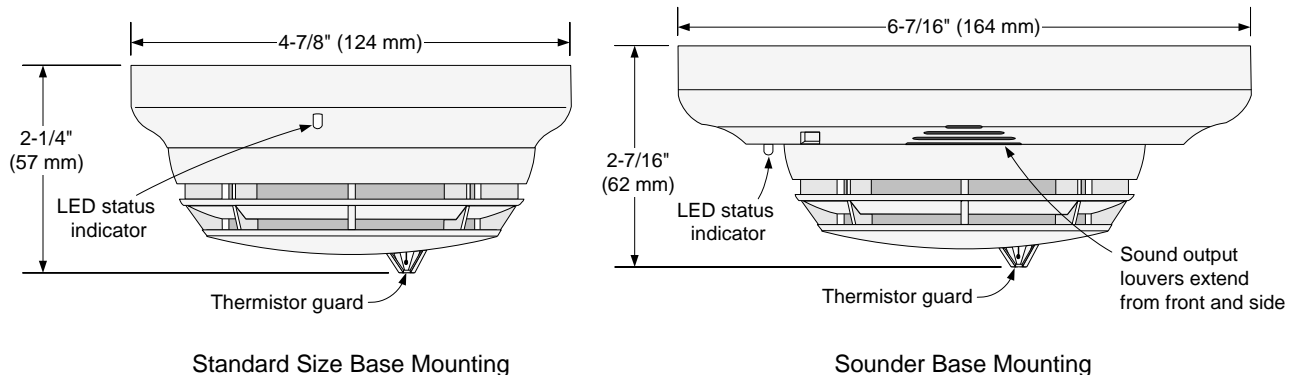

TYCO, SIMPLEX, and the product names listed in this material are marks and/or registered marks. Unauthorized use is strictly prohibited. NFPA 72 and National Fire Alarm and Signaling Code are trademarks of the National Fire Protection Association (NFPA).



Tyco Fire Protection Products • Westminster, MA • 01441-0001 • USA
www.simplex-fire.com

S4098-0024-10 6/2014

© 2014 Tyco Fire Protection Products. All rights reserved. All specifications and other information shown were current as of document revision date and are subject to change without notice.