



Air Release Valve





AN INTRODUCTION TO NAFFCO

NAFFCO was founded in Dubai, UAE to become the world's leading producer and supplier of life safety solutions. By recognizing the importance and convenience of having easy access to multiple safety services, we became specialized by offering complete solutions under one roof for all types of high quality firefighting equipment, fire protection systems, fire alarms, addressable emergency systems, security systems, custom-made vehicles such as fire trucks, ambulances, mobile hospitals and airport rescue firefighting vehicles (ARFF).

With the most talented and dedicated employees from around the world, NAFFCO has over 2,000 passionate engineers and over 6 million square feet of manufacturing facilities. We are currently exporting to over 100 countries worldwide.

NAFFCO manufactures UL, FM, BSI & Global Mark approved products in our facility in consistent with International Standards UL-DQS, BSI certifies for the Quality Management System against ISO 9001. Our Environmental (ISO 14001) & Occupational Health & Safety (ISO 45001) Management Systems have been certified by UL-DQS. Our Trucks & Vehicles division has been assessed & certified for Quality Management System requirement for Aviation, Space & Defense organization (AS 9100) by UL-DQS.

Our success is driven by our passion to protect; our vision is to become the world's number one provider of innovative solutions in protecting life, environment and property.

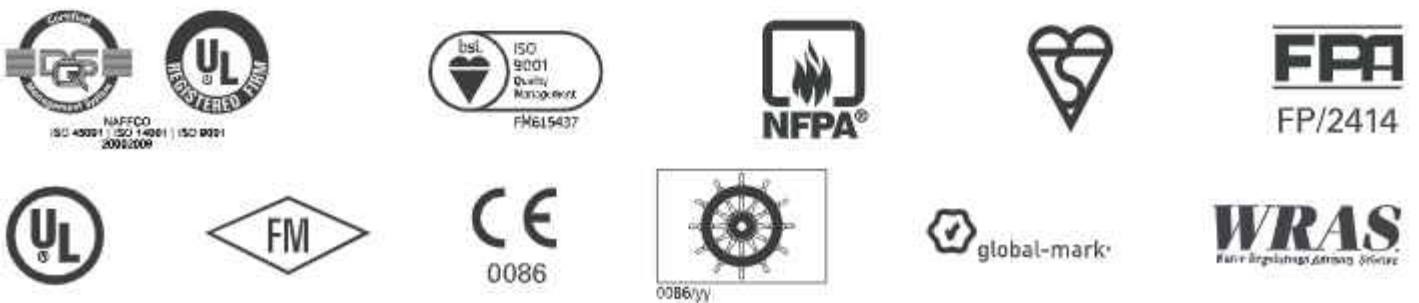

AIR RELEASE VALVES



INTRODUCTION

The construction of the NAFFCO Air Release Valve has been designed with stainless steel trim to give years of smooth operation. The Air Release Valve should be mounted at the high points in a piping system to automatically remove pockets of air as they accumulate. The valve can also be used to slowly release air in pump casings. This valve continuously eliminates air from a system by releasing small quantities of air before huge air pockets can happen. When continuous accumulations of air in the pipeline occurs (lacking air release valves) this causes the flow capacity to slowly decrease hence power consumption also slowly increases which is unnoticeable at first, until flow drops dramatically, which can even lead to complete stop of the flow due to large quantity of air. Another problem resulting from excessive air accumulation is un-explained pipeline rupture. These ruptures are passed off as the result of ground settling or defective pipe, where as in reality its large air pockets that greatly increase pressure surges (normally occurring) when flow stops and starts causing the rupture.

VALVE OPERATION

The NAFFCO Air Release Valve, as got, is a typically open valve and will gradually vent air through the orifice. As liquid enters the valve, the float will rise, consequently shutting the opening. As air aggregates in the piping system and enters the valve, the float drops enabling the air to be vented out through the opening. The lever component gives mechanical advantage to the orifice. Amid system operation, the pipeline pressure applies a solid upward drive on the sealing component, the orifice button. The lever instrument amplifies the heaviness of the float with the goal that the hole will open under high pipeline pressures. Extra ports are accommodated flushing, testing and draining purposes. This cycle automatically repeats as air accumulates inside the air release valve, thereby preventing the formation of air pockets.

INSTALLATION

The NAFFCO Air Release Valves must be installed at the system high points in the vertical position with the inlet down. For pipeline service, a vault with freeze protection, satisfactory screened venting, and drainage ought to be given. During closure, some liquid release will happen so vent lines should stretch out to an open drain area in plant service. A stop valve ought to be installed beneath the valve in the occasion of maintenance is required.

SPECIFICATIONS

Sizes:	1/2", 3/4", 1" NPT
Pressure Rating:	175 psi
Body and Cover	Ductile Iron ASTM A536 64-45-12
Float	Stainless Steel 316, ASTM A240
Internal Parts	Stainless Steel 316, ASTM A240
Orifice Button	EPDM
Paint Specification	Red Epoxy Painted
Operational Highlights	<ul style="list-style-type: none"> • Maintains system flow efficiency • Releases unwanted air pockets during system operation • Protects system against air related surges



AIR RELEASE VALVE - TECHNICAL DATA

MODEL NO.	VALVE SIZE	ORIFICE SIZE	INLET SIZE NPT	OUTLET SIZE NPT	MAX W.P
NF - 15 ARV	1/2"	1/16"	1/2"	1/2"	175 psi
NF - 20 ARV	3/4"	1/16"	3/4"	1/2"	175 psi
NF - 25 ARV	1"	1/16"	1"	1/2"	175 psi

AIR RELEASE VALVE - TECHNICAL DATA

Product Features:

- Unconditionally guaranteed stainless steel floats
- Stainless steel 316 internal trim
- Resilient seating for positive shut-off

When Ordering,

Please Specify:

- Inlet Size (NPT)
- Model Number

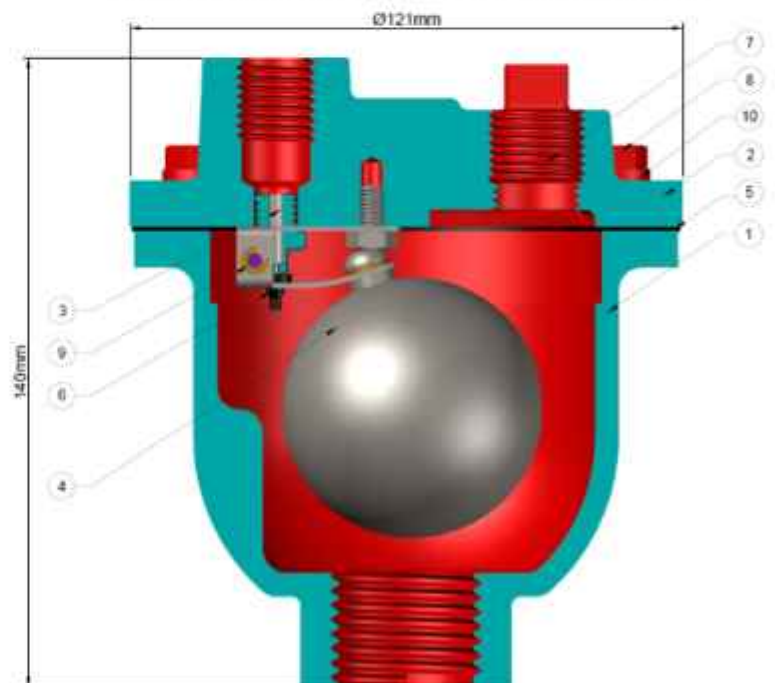

Detail No.	Part Name	Material
1	Body	Ductile Iron ASTM A536 65-45-12
2	Cover	Ductile Iron ASTM A536 65-45-12
3	Seat/Orifice	Stainless Steel 316, ASTJM A240
4	Float	Stainless Steel 316, ASTJM A240
5	Gasket	CN-705 (Non Asbestos-Gasket Material)

Detail No.	Part Name	Material
6	Orifice Button	EPDM
7	Pipe Plug	Ductile Iron ASTM A536 65-45-12
8	Cover Bolt	Alloy Steel SAE Grade 5
9	Circlip	Stainless Steel 316, ASTJM A240
10	Spring Washer for Cover Bolt	Stainless Steel 316, ASTJM A240



Serving Over 100 Countries Worldwide

NAFFCO

Email: info@naffco.com
www.naffco.com

In line with NAFFCO policy for continuous product development.



FOR ANY ASSISTANCE,
PLEASE CONTACT

800 NAFFCO

8 0 0 - 6 2 3 3 2 6

customerservice@naffco.com